

CAD FILE:

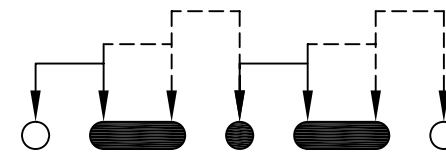

SCHEMATIC (NON-SHORTING)

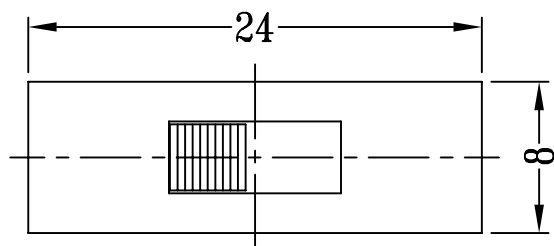
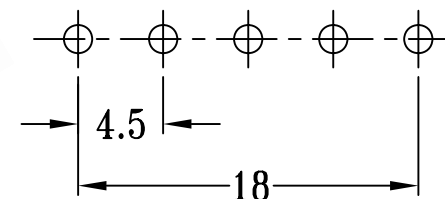
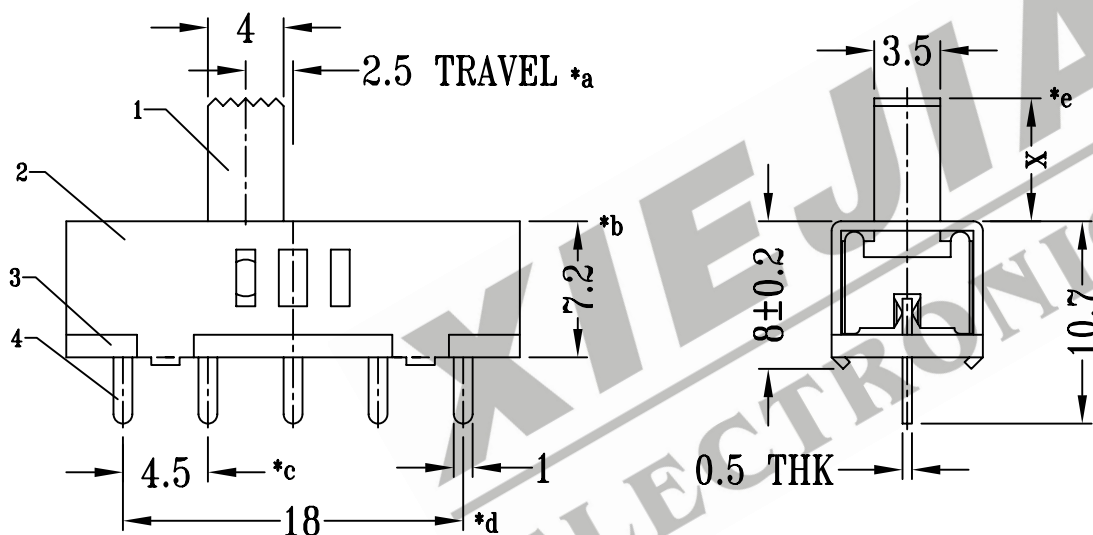

P.C.B LAYOUT

注:带"*"表示关键尺寸(5个)

NO.	PARTS	MATERIALS	Q'TY	FINISH	TOLERANCE UNLESS SPECIFIED	SHENZHEN XIEJIA ELECTRONICS CO.,LTD.					
8						ISSUE		DATE		DESCRIPTIONS OF REVISION	APPD.
7	STEEL BALL	STEEL	2	NATURAL	WITHIN: 1.5±0.1mm	TITLE : VERTICAL SLIDE SWITCH		UNIT : mm	DRWG NO.: XJ-DR-SS23E16-00		
6	SPRING	STEEL WIRE	1	TEMPER	OVER : 1.5±0.2mm	MODEL: SS-23E16		SCALE: 5:2	DWN.	ZHOUYU	2004-11-19
5	CONTACT CLIP	PBS	2	Ag CLAD					CHK'D	FANGYING	2004-11-19
4	TERMINAL	BRASS STRIP	5	Ag PLATED OVER Ni PLATED		ALL MATERIALS MUST BE COMPLIANT TO ROHS			APPD.	KANGXINAN	2004-11-19
3	BASE	PHENOLIC RESIN	1	NATURAL							
2	FRAME	STEEL STRIP	1	Ni PLATED							
1	KNOB	PA66	1	BLACK							